

REGULATOR ROPES AND TENSIONING SYSTEM

REGULATOR ROPE CHOICE

The most important safety mechanism group of elevators are safety gear and regulator system. This safety system is the most important difference between elevators and lifting cranes. An elevator that the relevant system is not installed properly into cannot be considered as an elevator but just a lifting crane. For this system to run together safely depends on the proper use and connection of regulator rope which connects those each other. Regulator ropes are defined in EN 81-20 Standard Article 5.6.2.2.1.3 in particular. Properties and strength values of the rope are stated in the first two paragraphs.

“ EN 81-20, 5.6.2.2.1.3 Overspeed governor ropes

The rope of an overspeed governor shall satisfy the following conditions:

- a) the overspeed governor shall be driven by a wire rope as specified in EN 12385-5.*
- b) the minimum breaking load of the rope shall be related by a safety factor of at least 8 to the tensile force produced in the rope of the overspeed governor when tripped taking into account a friction factor μ_{max} equal to 0,2 for traction type overspeed governor.*
- c) the ratio between the pitch diameter of the pulleys for the overspeed governor rope and the nominal rope diameter shall be at least 30.*
- e) during the engagement of the safety gear, the overspeed governor rope and its terminations shall remain intact, even in the case of a braking distance greater than normal.”*

According to the Article, the first condition is that the regulator ropes are subject to EN 12385-5 standard. When we examine this standard, we see that suspension ropes defined in Chart 6 and Chart 7 for the regulators. A calculation for common elevator systems will be made here. In elevators that are high-speed or have long running distance, regulator rope fluctuation appear as a different problem. For these kinds of elevators, more different tensioning weight and rope diameters should be used. As long as there is not a such full-featured elevator, we should accept that we would mostly choose the regulator ropes among the ones that are 10 mm.

Rope Nominal	Approximate Bulk	Min. Breaking Strength N	Min. Breaking Strength N
Diameter mm	kg/m	(1570 strength calss)	(1770 strength calss)
Chart 6, 6*19 Fiber cored ropes			
6	0,129	18700	21000
6,5	0,152	21900	24700
8	0,23	33200	37400
9	0,291	42000	47300
10	0,359	51800	58400
Chart 7, 8*19 Fiber cored ropes			Chart 8, 8*19 Steel cored ropes 1770
8	0,218	29400	40300
9	0,275	37300	51000
10	0,34	46000	63000

For these ropes, unit rope weight and the minimum breaking values for 1570 N/mm² strength class -which compose the relevant parts of Chart 6 and Chart 7- are given in the table below. The standard should be examined regarding the minimum breaking strength of ropes with strength class 1180/1770, 1370/1770, 1770 N/mm². This table is provided for information purposes to explain the general calculation.

For the first condition mentioned in the article, the ropes to be used should have the above mentioned properties. Every steel rope is not in conformity with the terms of EN 12385-5 standard thus, it is necessary to request certificate of conformity to the relevant standard from the supplier. Another term related to the same situation states that the diameter of regulator pulleys (bottom tension pulley and upper locking pulley) should be at least 30 times bigger than the rope diameter. Besides, connections of the ropes should be in conformity with the standards. These terms should be primarily ensured.

For the second term stated in Paragraph (b), it is needed to calculate rope safety factor with the value of $\mu=0.2$. As it is known, the friction value of $\mu=0.2$ is the blocked status term (EN 81/50 M 5.11.2.3.2). In this case, it is required to calculate the forces occurred on the regulator and the friction coefficient. Forces occurring on a friction driven system are calculated with friction coefficient.

$$T_1 = (e^{f\alpha} * T_2)$$

For $T_1 = (e^{f\alpha} * T_2)$ calculation, T_1 is the hanging force on the rope pulling the brake mechanism arm occurring as a result of the distortion of T_2 force with the $e^{f\alpha}$ friction coefficient (developing upon the friction in regulator groove). T_2 is the force that is formed as a result of the rope weight and tractive power which is created by the regulator tensioning weight on rope arm. T_1 force -that will occur when the regulator is locked- is desired to be less than the 8 times of the rope's smallest breaking strength. That means: It should be

$$HK/T_1 > 8 \quad (\text{HK Rope min. breaking strength})$$

The condition for regulator tensioning weight to pull downward with a force of 300 N to upward breaking requires it to create a 300 N force on the rope arm that provide movement towards the other side. In this case for a normal application, the total force should be 600 N on the regulator tensioning and 300 N should be distributed for each rope arms (this calculation is different in the systems which do not perform the upward braking from the car). If we assume that we use a 6 mm rope for an elevator having 60 mt length of well, the rope weight will be:

$$M = 60 * 0,129 \text{ kg (from the Table)}$$

$$M = 7.74 \text{ kg} = 75.93 \text{ N (for thin ropes and low rise buildings, half of the rope load could be considered.)}$$

Total T_2 force will be

$$T_2 = 300 + 75.93 = 375.93 \text{ N}$$

In order to see the rope safety force, friction coefficient should be calculated. $e^{f\alpha}$ value is determined based on the well angle of the governor you use. We know that twist angle α is 180 degrees and radius is $\pi = 3.1415$. We need to calculate f value and find $e^{f\alpha}$ value.

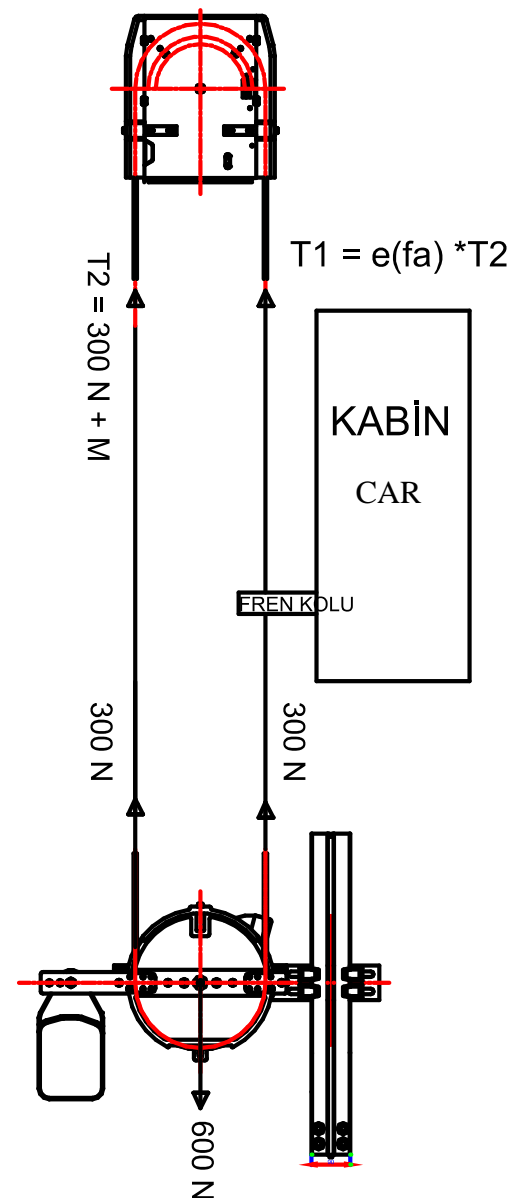

Let's consider the groove angle of the governor is 38 degrees.

When the cabin is blocked,

We find f with the below calculation:

$$f = \mu \cdot (1/\sin \gamma/2) \text{ (hardened and unhardened grooves)}$$

$$f = 0,2 \cdot (1/\sin 38/2) = 0,2 \cdot (1/0,325) = 0,615$$

$$e^{f \alpha} = e^{(0,615 \cdot 3,1415)} = e^{1,9320} = 6,903$$

$$e^{f \alpha} \cdot T_2 = 6,903 \cdot 375,93 = 2595,04 \text{ N}$$

In this case, when the system is locked, a maximum pulling force of $T_1 = 2595.04 \text{ N}$ will be generated. The rope can start slipping from the locked governor sheave only after the cabin generates traction against this force. During the suspension of the cabin, the rope is required to provide 8 times more safety. The smallest breaking force of the rope should be 8 times more than this force. As the breaking force of the 1570 N/mm^2 6 mm rope we use is 18700 N (from the table)

$$\text{Breaking Force} / T_1 > 8$$

As $18700/2595.04 \text{ N} = 7.20 < 8$, the standard **does not** satisfy the condition. In this case, instead of using a 1570 N/mm^2 6 mm rope, a 1770 N/mm^2 6 mm rope should be used.

When we again make a calculation considering that the smallest breaking force of the rope is 21000 N , then the breaking force should be $\text{BF}/T_1 > 8$.

As $21000/2595.04 \text{ N} = 8.09 > 8$, then the standard is conformed. For buildings with 14-15 storeys where a 6mm rope is used, half of the rope load could be considered as the rope impact is small. In this case, we find:

$$T_1 = e^{f \alpha} \cdot T_2 = 6,903 \cdot 337.96 = 2332.93 \text{ N}$$

As $18700/2332.93 = 8.01 > 8$, then the standard is conformed. However, it is obvious that the safety coefficient is at a limit value in both cases. For 6 mm ropes, 60 meters of rope length could be considered as the upper limit at a normal tensile force while 50 meters is considered as a safer length which is equal to the length of a 14-15 storey building. When a normal rope of 1570 N/mm^2 is used, it will be safer if the shaft length does not exceed 40 meters. Practically, for the elevators with dual brake, increasing the diameter of the regulator rope should be considered as a suitable solution in the distances where balance chain is needed.

Besides, tensile control must be done for the preferred rope. The following formula can be used benefiting from the tensioning and stretching relationship formula for the rope tensile.

$$\sigma = E \cdot \varepsilon, \quad \varepsilon = l/l_0, \quad \sigma = E \cdot l/l_0,$$

$$l = (F \cdot l_0) / (E \cdot A)$$

$$\mathbf{L\% = (F_{max} \cdot l_0) / (E \cdot A)} \text{ (L\% value should not be over 1\%.)}$$

$$l_0 = \text{Rope length (mm)}$$

$$E = 63000 \text{ N/mm}^2 \text{ Elasticity module for steel rope}$$

$$A = (\pi \cdot d^2 \cdot x) / 4 \text{ mm}^2 \text{ Real area of rope} \quad x = 0.49 \text{ 6x19 for ropes, } x = 0.44 \text{ 8x19 for ropes}$$

For this calculation, we need to find F_{max} value. F_{max} value is composed of the force that is formed as a result of the rope weight and tractive power which is created by the regulator tensioning weight on rope arm. L% value of this force should be less than 1%.

$$M = 75.93 \text{ N}$$

$$F_{\max} = 300 + 75.93 = 375.93 \text{ N}$$

$$L\% = (F_{\max} \cdot l_0) / (E \cdot A)$$

$$L\% = (375.93 \cdot 60000 \cdot 4) / (63000 \cdot 3.14 \cdot 36 \cdot 0.49 \cdot 100) = 0.2584 < 1$$

We can accept that the rope used is appropriate. One of the reasons that the regulator ropes stretch too much is that the ropes used are not in conformity with the standard of EN 12385-5 as they are softer ones. There will certainly occur a stretch in all ropes but attention must be paid to two points.

1. In elevators that string-loaded tensioning is used, stretch occurs due to the suspension of tensioning system rope with a force of 300 N even though the stretching contact reaches until the cutting point when the rope stretches. If you do not control this value before installing the tensioning, you can get injured seriously. Stretching rope takes the tensile force and they stay in such a balanced situation that you may think the rope is tense but it is not that tense to engage the brake, Regulator of the elevator turns into a cancelled situation.
2. It will not be possible to rope safety coefficient if soft rope is chosen in terms of financial reasons. Thus, the rope may break off during a braking moment. This may cause the most unsafe situation for the elevator.

Mechanical brake and regulator kit are the most important ones among the primary safety mechanisms in elevator. Operation of all system depends on the intermediate regulator rope. Cost calculation for this group should be kept in the background and safety should be in the forefront. There are lots of materials to decrease the costs in elevator but for safety components, this should be kept in the background a little bit more. Attention should be paid while choosing brake, regulator, tensioning set and regulator rope. What distinguish elevator from lifting crane are these safety components. As elevator operators respecting our job, we should be sensitive to this subject.

Can overspeed governor rope thickness be less than 6 mm?

In the previous standard, EN 81-1+A3, it was stated that regulator rope should be steel rope and that its thickness should be at least 6 mm in the articles related to speed regulator rope.

“ EN 81-1A3, 9.9.6 Overspeed governor ropes

9.9.6.1 *The overspeed governor shall be driven by a wire rope designed for that purpose.*

9.9.6.3 *The nominal rope diameter shall be at least 6 mm.*

However, these articles have changed in the new standard that replaced it and we still use which is EN 81-20 standard. The first term is that instead of steel rope, the rope which is in conformity with EN 12385-5 standard was put into use and 6 mm restriction was removed.

“ EN 81-20, 5.6.2.2.1.3 Overspeed governor ropes

The rope of an overspeed governor shall satisfy the following conditions:

- a) the overspeed governor shall be driven by a wire rope as specified in EN 12385-5. ...”*

In the relevant rope standard, regulator ropes can be chosen as suspension ropes among the Chart 6 “6*19 ropes” and Chart 7 “8*19 ropes” as the well as thicker ropes in Chart 9 and Chart 10. Attention must be paid to choose suspension ropes from among Chart 6 and Chart 8. The thinnest rope to be used is given as 6 mm in these charts. For regulators, 6 mm rope restriction was removed from the standard but it is given based on to the other standard. There is not a rope description thinner than 6 mm in EN 12385-5 standard.

The same elevator can create different conditions as in the situation of suspension ropes. EN 81-20 standard states that suspension ropes to be used based on the EN 12385-5 standard cannot be thinner than 8 mm. Nevertheless, ropes with different properties are certificated **as elevator ropes** (not as steel rope) after tested by Notified Bodies and obtaining the approval of “can be used as elevator suspension rope” and the ropes thinner than 8 mm which are 6.5 mm can be used as elevator suspension ropes. Ropes thinner than 6 mm which are tested by the Notified Bodies and obtained the approval of “can be used as elevator suspension rope” and “certificated as elevator suspension rope” can also be used as regulator ropes in the same way. However, they have to ensure the relevant strength restriction of the Article above.

“ EN 81-20, 5.6.2.2.1.3 Overspeed governor ropes

- b) *the minimum breaking load of the rope shall be related by a safety factor of at least 8 to the tensile force produced in the rope of the overspeed governor when tripped taking into account a friction factor μ_{max} equal to 0,2 for traction type overspeed governor.”*

The study related to this calculation was made in the first section of the paper. Purpose of this paper is not for the use of ropes thinner than 6 mm, but for the use of thicker ropes according to the calculation. A rope thinner than 6 mm ensuring the general terms of Article 5.6.2.2.1.3 and sufficient strength value and having the certificate of “elevator rope” obtained from a Notified Body can be used in this situation, but cost of this rope will be higher than the normal 6 mm rope. A thinner steel rope with normal restriction and without an elevator certificate cannot be used.

Another question that is asked is that “why the whole rope weight is taken in the calculation of regulator stretching”. In the calculation of the weight that has effect on the rope’s itself, it requires to take its half since the load is distributed equally but many tensioning weight pulls with a strength more than 600 N. The whole weight of the rope was taken to form the worst condition and facilitate the calculation. Moreover, the shakings during the movement are thusly taken into account as well. Though, it is required to avoid from solutions very close to the 8 safety coefficient. This part is not one of the parts that should be included in a fine cost calculation.

Should regulator weight tension contact be a locked contact?

We should firstly understand the operating principle of an elevator. One of the primary properties that distinguish an elevator from a lifting crane is the ensuring of the car’s impact safety through a mechanic braking system (safety gear) connected to the car. As long as mechanic braking system is not active, the car is not moved in any way. (Elevator Directive Appendix 1). This rule also applies for during the installation. Elevator companies should write this term into the installation instructions and control it. Car frame should not be moved before the regulator and brake is activated. Many incidents are caused by the operations performed before ensuring this condition. Operation of mechanic brake depends on the regulator but if the regulator is active, it can control the linkage. Operation of the whole system depends on if the regulator tension pulley keeps the regulator rope tense. If the rope is tense and hangs with a sufficient weight, only then the regulator can operate and activate the safety gear device. Thus, regulator tensioning system is the main component among the most important ones.

Control of whether the regulator rope is tense should be executed with a safety contact. This contact must engage in when the regulator rope breaks off or stretches considerably and suspend the elevator engine (EN 81-20 M 5.6.2.2.1.6). Since it is a machinery enabling the operation of safety system, it is a contact that is not short circuited in any case and is in the lead of safety chain. As it is known that although the regulator upper contact, safety gear contact, final limit switches, buffer contacts and door contacts for leveling can be short circuited for electrical emergency retrieval operations, the mentioned contact is not short circuited under any circumstances. Its safety circuit is stopped when it cannot operate, the elevator stops and is not moved before adjusting that contact. Because, operation of mechanic brake depends on whether the tensioning system is active. Short circuit should not be used by no means.

During braking, bouncing as well as stretch in the regulator tensioning weight due to the hitting or bouncing due to the movement may occur. Following this situation, if the rope is not in a state to operate, the elevator should not be driven but if the rope turns back to its place again after bouncing, retrieval can be performed in the elevator through electrical emergency retrieval. Because the retrieval in synchronized engine systems commonly used today or high-capacity elevators can only be possible through electrical emergency retrieval. In case a locked contact is used in regulator weight, an electrical emergency retrieval cannot be made since the safety circuit chain will be switched off in the first place upon bouncing. Short circuiting this circuit will extremely be a false application since it is a circuit including the stops. The suggestion that “it is required to control this circuit before retrieval” is an abstract thought and does not apply for field practices. Who does climb down 20 storeys before every breakdown reporting, look at the contact and then climb up again and perform retrieval? This should be reflected upon. If a locked contact has to be used in tensioning system, then changing the form of safety circuit should be considered in this case. A separate contact that will control the rope stretching or breaking off and will be placed on top of the safety circuit chain must be used; this contact must certainly engage in when the rope stretches or breaks off while the locked contact used in the joint should be displayed on the diagrams in a way not to prevent electrical emergency retrievals upon bouncing through connecting in the area where the manual retrieval is short-circuited (to the parachute contact, final limit switches section). Without making an adjustment like this, locked contact should not be used in tensioning systems through using a normal system.

Can regulator tension systems be spring-loaded?

Regulator have been progressing to a very problematic state in tensioning systems recently. One of the responsibilities of tensioning system is to keep the rope tense but another important responsibility is to ensure at least a pulling of 300 N for the rope arms connected to the braking device in the systems performing especially the upward braking in the cabin. As a result of an approximate calculation, if there is a need for at least 30 kg suspension load on a rope arm, a suspension load of 60 kg at the center of the tension pulley since 30+30 kg load will be required on each arms. This load is the one that should be ensured in the position of tension pulley at a point where the tensioning contact will engage in upon the rope stretching, not while the tension pulley stays parallel to the ground. Because the tension weight has to continue its capacity like this so long as the tension pulley does not switch of the circuit. Tensioning angle changes after the rope stretching in jointed arm weighted systems but we can still observe that a 90% part of the hung weight is still active since the $\cos 25^\circ$ value give 0.90 value even in the angles of 25° after the stretching. Thus, it will be enough to keep the requested weight 10% more in the weighted systems for solving this problem.

However, the situation differs for spring-loaded systems. So, this becomes more of an issue. In the case of a spring-loaded system, the spring should ensure the tension weight needed for the rope arms in the last stretching point where the contact will engage. However, though the springs ensure this load when they stretch and the tension pulley arm is parallel to the ground in many spring-loaded system, the loads that will stretch the rope in the tension pulley rapidly decreases together with the closing of the springs when the rope stretching starts. After some time, a balance develops between the tractive power of the springs and stretching force of the rope while the stretching of the rope stops. However, the tension force of tension pulley decreases to 150 N value instead of staying as 600 N and thus a value which is far below the tension value that will enable braking as a tractive power occurs on the rope arms. Since this balance situation develops especially after the stretching, spring-loaded tensions are started to be used widely by the service men who are freed from distress of shortening the regulator rope. The most deceptive point of it is that the regulator rope stays as if it is tense when the stretching of the rope reaches to the balance point and does not show any need for an intervention.

While, in fact, the rope's tractive power that develops on the tension pulley has already lost the tension that can engage the brake. The service men are happy to be freed from the trouble of shortening the rope while the elevator has already become far from being safe anymore. Thus, the brakes are not activate especially upward as well as downward in the situation that rope tension decreases to much in each brake test for the elevators that uses these systems. When everybody calls the brake manufacturers and asks the reason of it, the manufacturers loosen the car brake mechanism's springs or brake springs. Nobody elaborates on that actually the regulator tensioning system does not work.

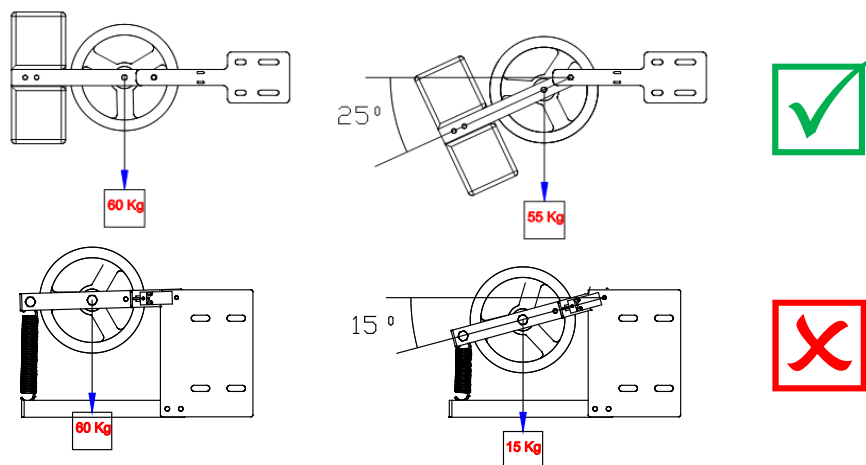

Even if the rope stretches in a weighted tensioning system, the weight changes are around 10%.

However, even a lesser rope stretching removes the tension weight in many spring-loaded system.

In this case, most of the brake and regulator systems of elevators that uses short springs and in which a spring-loaded tension that lost its capacity to pull during the slightest rope stretching is used are in a state of shut down. I would like to make a very crucial warning. Brake and regulator systems of the elevators that uses these kinds of spring-loaded tension system are in a state of shut down. All of them work as a lifting crane. Unfortunately, the number of elevators that will crash to the top or bottom of the well with the mechanic brake fail will increase in the next days. The ones that use this system should constantly perform controls, otherwise they may experience troubles beyond measure.

It is required that the springs still develops 60 kg tractive power at the center of the regulator pulley in case that tension pulley reaches to the cutting point of regulator tension contact as a result of regulator rope stretching if the spring-loaded tensions are used. There is no objection to use tension spring systems that ensures this condition. Thus, it is required to use systems which are long-bowed and in which the pulley arm's tension margin stays within the powerful flexing margin of the spring and does not lose its force at the end of the tension margin. Otherwise, undesirable and unsafe situations will occur.

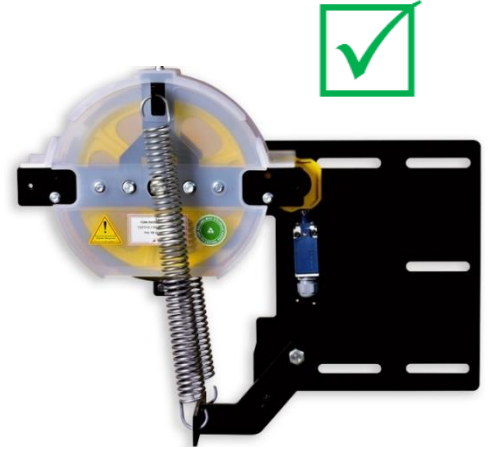

Respectfully yours,
Serdar Tavasliođlu
Elc. Eng.

DISCLAIMER

This manual is intended as a means for providing help for regulator ropes and tensioning system in elevators. This manual is not intended for replacing the will of the lift technician designing the lift for their own examinations and assessments and making their own decisions. Serdar Tavasliođlu, as the compiler of this document, declares that I shall not accept any responsibility for measures that are taken or not taken based on this manual.